



FALL 2015 AUCTION

No Starting Bids and No Hidden Reserves!

Seller Orders Significant Price Reductions!

MINIMUM BIDS FROM \$445,000 to \$485,000

Two New Oceanfront Three Bedroom, Three Bathroom Condominiums, and Adjoining Oceanfront Development Site



- Within two hour drive of Portland and ninety minute drive of Salem
- Spectacular views south to Proposal Rock and Cascade Head

	3 Bedroom 3 Bath Condominiums		10,000 S.F. Oceanfront Development Site
	#100	#101	#102
MINIMUM BID:	\$445,000	\$455,000	\$485,000
LAST ASKING PRICE:	\$619,000	\$619,000	\$728,000

Open House Dates	
Sunday, October 11	11:00 am to 1:00 pm
Saturday, October 24	1:00 pm to 3:00 pm
Sunday, November 15	11:00 am to 1:00 pm

SEALED BIDS DUE NOVEMBER 18, 2015

Broker Cooperation Invited

Call For Free Color Catalog #1504 and Bid Package #100-102

1-800-845-3524

Auction conducted by:

REALTY MARKETING/NORTHWEST, Broker

522 SW 5th Avenue, Suite 725 Portland, Oregon 97204



FALL 2015 AUCTION

No Starting Bids and No Hidden Reserves!



Expansive views from kitchen and great room, which includes fireplace. First floor has bedroom and full bathroom. Second floor has two master bedroom suites, and laundry area.

Lower Level

First Floor

Second Floor

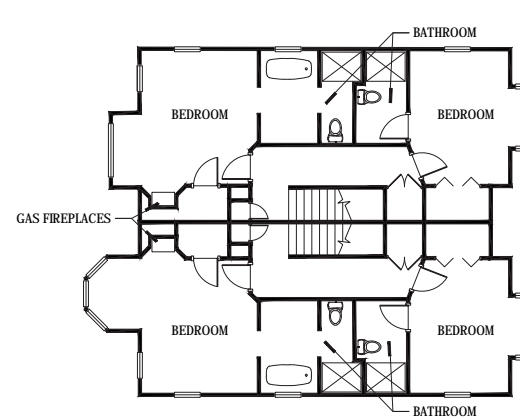
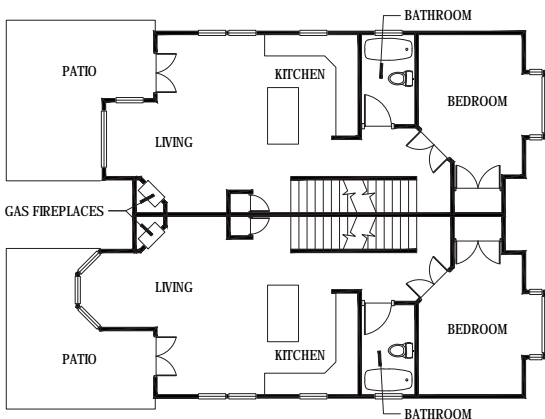
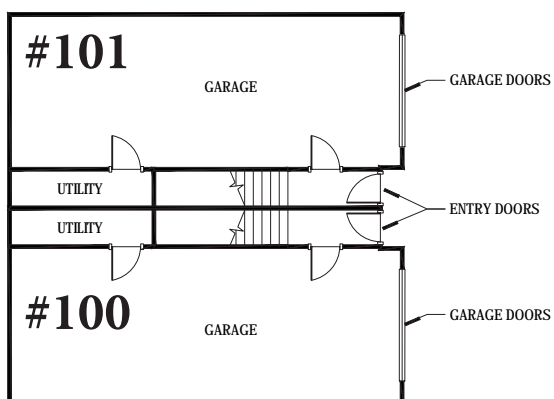

Both condominiums have identical floor plans, each with 1,463± square feet of living space on two floors, and a lower level with main entry plus garage that can accommodate two cars. Auction Property #101 is being sold with all appliances. In addition, the furniture package is available for \$15,000.

#102 – Infill Development Site

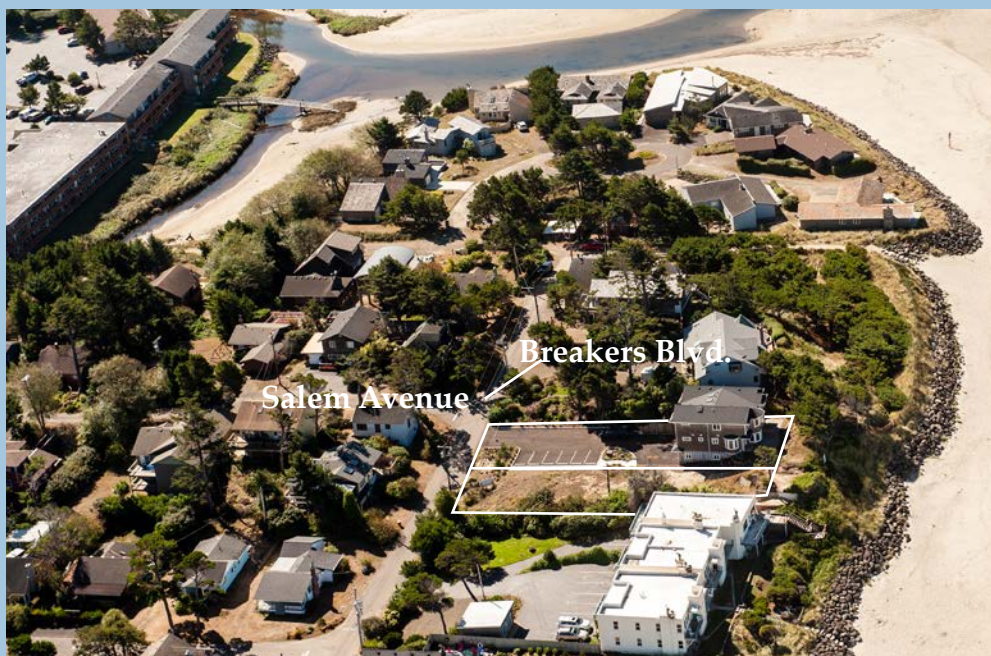

10,000± square foot oceanfront development site can accommodate two homes – geotechnical report is available in Supplemental Information Package.



SEALED BIDS DUE NOVEMBER 18, 2015

Broker Cooperation Invited

Call For Free Color Catalog #1504 and Bid Packages #100-#102

1-800-845-3524

Auction conducted by:

REALTY MARKETING/NORTHWEST, Broker

522 SW 5th Avenue, Suite 725 Portland, Oregon 97204